



[560 x 14 mm]

INTRODUCTION

LED module is an advanced light source designed for the best energy efficient and eco-friendly indoor lighting. It is based on medium power LEDs produced by the leader of the LED technology. Using newest technology we provide the best solution for lighting. With a very high value of CRI and simple installation. Connecting few LED modules allows to create complex lighting. Push terminals provide quick installation of the entire lighting system. This solution is the best for indoor ceiling-mounted and wall-mounted luminaire.

LED Type	Samsung LM302C
LED Quantity	24 pcs
Dimension	559,5x14 mm
Power Supply Type	Constant Current (CC)
Input Current	max.1800 mA
Viewing Angle	120°
Material Thickness	1,5 mm
Cable Connection	Terminal blocks
Max Ambient Temperature	45°C
CRI	>80
Manufacturing Site	Cezos, Poland, Europe

FEATURES

LEDs have significant advantages compared to other types of lighting and are easy to use. LEDs are versatile and virtually maintenance free.

- Efficiency of the module up to 179 lm/W @ 1050 mA
- Rigid board LED module
- Viewing angle at 50% I_v: 120°
- High colour rendering index CRI >80
- Small colour tolerance
- Small luminous flux tolerances
- Colour temperatures 2700K, 3000K, 4000K, 5000K
- Push terminals for quick and simple wiring
- Dimmable
- Simple installation
- Long lifetime

APPLICATIONS

- Ideal for ceiling-mounted and wall-mounted luminaires
- Retrofits and fixtures
- Accent and Effect Lighting
- Professional downlights
- Shop lighting



CALCULATED PARAMETERS AT $T_J = 25^{\circ}\text{C}$ AND $T_J = 65^{\circ}\text{C}$

Input Current [mA]	Forward Voltage [V]	Power [W]	CCT [mA]	Typ. CRI	Luminous Flux* [lm]	Module Efficacy* [lm/W]	Luminous Flux** [lm]	Module Efficacy** [lm/W]	Article Number
1050	12	12,6	2700	85	2010	159	1915	155	L0-560014-827-C1800-Xxxx
			3000	85	2010	159	1915	155	L0-560014-830-C1800-Xxxx
			4000	85	2136	169	2034	164	L0-560014-840-C1800-Xxxx
			5000	85	2261	179	2154	174	L0-560014-850-C1800-Xxxx
1200	12,1	14,6	2700	85	2267	156	2159	151	L0-560014-827-C1800-Xxxx
			3000	85	2267	156	2159	151	L0-560014-830-C1800-Xxxx
			4000	85	2408	166	2294	161	L0-560014-840-C1800-Xxxx
			5000	85	2550	175	2429	170	L0-560014-850-C1800-Xxxx
1400	12,3	17,2	2700	85	2598	151	2474	147	L0-560014-827-C1800-Xxxx
			3000	85	2598	151	2474	147	L0-560014-830-C1800-Xxxx
			4000	85	2760	161	2629	156	L0-560014-840-C1800-Xxxx
			5000	85	2922	170	2783	165	L0-560014-850-C1800-Xxxx
1600	12,4	19,8	2700	85	2969	150	2827	143	L0-560014-827-C1800-Xxxx
			3000	85	2969	150	2827	143	L0-560014-830-C1800-Xxxx
			4000	85	3154	159	3005	151	L0-560014-840-C1800-Xxxx
			5000	85	3340	169	3182	161	L0-560014-850-C1800-Xxxx
1800	12,7	22,5	2700	85	3340	148	3181	141	L0-560014-827-C1800-Xxxx
			3000	85	3340	148	3181	141	L0-560014-830-C1800-Xxxx
			4000	85	3549	158	3380	150	L0-560014-840-C1800-Xxxx
			5000	85	3758	167	3578	159	L0-560014-850-C1800-Xxxx

* - Parameters were calculated for temperatures $T_J = 25^{\circ}\text{C}$

** - Parameters were calculated for temperatures $T_J = 65^{\circ}\text{C}$

Value of these parameters were calculated for default bin and with tolerances of 15%.

Parameters shown in table above are default and for temperatures $T_J = 25^{\circ}\text{C}$ and $T_J = 65^{\circ}\text{C}$. Some of these parameters are temperature dependent and can be different during long time of operation. So it is impossible to order modules with the same parameters after some time. LED technology is developed fast and producers are creating new LEDs with better features very quick. If you need LED modules with different value of some parameters, we provide other LEDs with different colour temperature and features. It is possible to make modification of LED modules or create a new one. In such cases and for more information, please contact us before ordering. Please have all of this in mind when ordering LED modules.



MACADAM ELLIPSE

Producing LEDs with the same colour temperature is almost impossible. LEDs with similar colours are divided into bins. MacAdam Ellipses are used to describe differences in colour of LEDs with the same bin. When most people can't see very small differences in colours, these colours are in first step level of MacAdam Ellipse (1SDCM). If the differences are getting bigger, then number of step is increasing. Second zone of MacAdam ellipse (2SDCM) is twice bigger than first one and so on. Differences in colour for 3000K LEDs can be up to $\pm 30K$ in 1SDCM. If bin is in 4SDCM, then colour differences should be less than $\pm 100K$. LEDs with smaller number of SDCM are better. Most common LEDs are in 4th to 7th step level, in other words human eyes certainly can see colour differences in LEDs that are ostensibly the same colour. In most of our projects have been used LEDs in 3rd step level, so differences in colour aren't as big as fourth step level of MacAdam Ellipse.

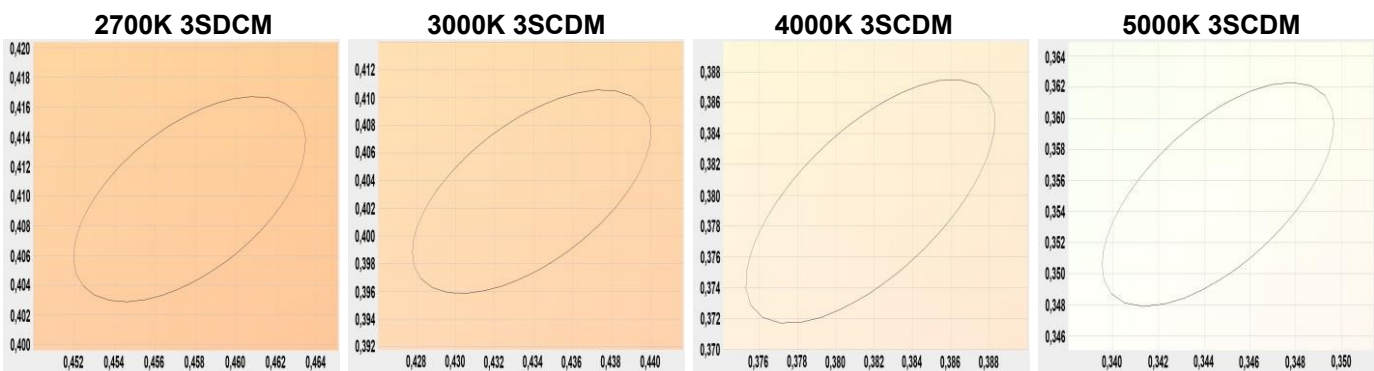

SAFETY

Most of LEDs generate high intensity light even when dimmed. If LED light has high intensity, it is classified as laser. These LEDs must have appropriate marking. Combination of LEDs or even weak LEDs with optics can be very dangerous, because optics can focus beam and looking into LEDs beam is unhealthy and may cause irreversible injury to eye's retina. Never look into the beam without protection glasses with appropriate filter.

Additionally LED light can change intensity almost immediately. If people are photosensitive, LED light may be a trigger to epileptic seizures and alter the perception, especially when light changes very fast.



PROTECTION MEASURES AGAINST DAMAGE

LED modules are delicate, even small mechanical stress may damage modules. Especially sensitive are LEDs. Such stresses should be avoided. If it is impossible, it should be reduced to minimum. Mechanical stresses such as pressure, bending, breaking, drilling, etc. may cause irreversible damage. Damaged LED modules aren't suitable for use.

Serious threat to LEDs is ESD. People generate very high electrostatic voltage. Such voltage decreases lifetime of LEDs and in worst case may destroy electronic components. Best way to avoid damage is use of electrostatic protection. Do not touch electronic components.

Additionally LED modules can be damaged by some chemical substances. Depends of elements the damage may be different. It is important not to use chemical substances like acids, organic acids, sulphur, alkalis, organic solvents, mineral oils, vegetable oils and synthetic oils, etc. We are not responsible for any loss, or damage resulting from improper use of modules! Guarantee become void in such cases.

Do not operate LED modules, when they aren't working properly. If modules are working incorrectly, turn off power supply. Damaged LED modules may cause electric shock or short circuit.

CONNECTIONS

Connecting few LED modules allows to create complex lighting. Push terminals provide quick installation of the entire lighting system. The LED modules must be operated with power supply that is suitable for LEDs. When connecting a few LED modules use of appropriate power supply is important. Power supply should have sufficient maximum power to maintain all LED modules. Power supply must be connected properly. Wrong polarization can destroy modules in very short time. We are not responsible for any loss, or damage resulting from improper use of modules! Guarantee become void in such cases. Modules can be operated using a LED controller. It allows to use light effects, dimmer, etc. Thanks to dimmer it is possible to eliminate almost immediately change of light intensity. It is possible because LEDs are full controlled. Slower changes of light intensity are more safety for people with photosensitivity. We have got several different dimmers like touchable, RC, IR and Bluetooth in our offer. Most controllers have many light effects such as fire, thunderstorm, rainbow changes, strobe, etc. Some of these allow to create new effects, that are programmable via software.



WIRING DIAGRAM FOR LED CC MODULES WITH SERIAL WIRING



Advantages of this solution are very effective operation and uniform distribution of light. Higher voltage supply is require, when large number of LED modules are connected. If too many LED modules are connected, the voltage value may not meet requirements of SELV. Non-SELV voltage need additional protection. All above connections are examples and may be different from the actual.

WIRING DIAGRAM FOR LED CC MODULES WITH SERIAL - PARALLEL WIRING

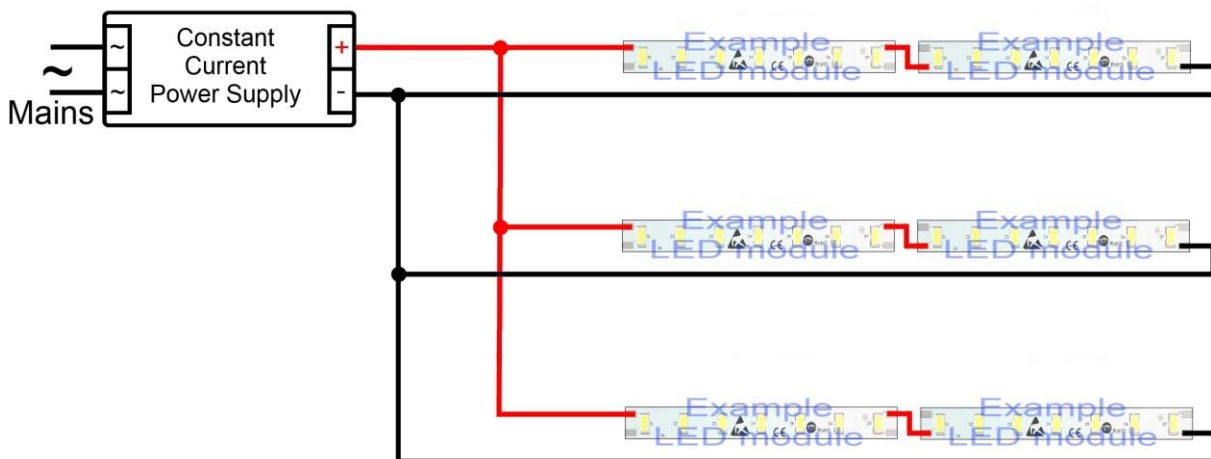

Serial connections must have same number of LED modules in every series. This solution need less voltage supply than serial wiring with same number of LED modules. Higher current supply is require to proper operation. Disadvantage of this solution are patchy distribution of light and different lifetime of LEDs. Especial when one or more LED modules are damage, because distribution of current in the system is patchy. Higher current increases temperature and decreases lifetime. If too many LED modules are connected in serial, the voltage value may not meet requirements of SELV. Non-SELV voltage need additional protection. We are not responsible for any loss, or damage resulting from improper use of modules! Guarantee become void in such cases. Above connection is examples and may be different from the actual.



COOLING

The modules are usually self-cooling but if temperature on T_c point exceeds 70°C , then a heat-sink is required. Temperature test point (T_c) for measurement should be localized in the middle of the board near LED's thermal pad. The temperature at the T_c point can be measured with thermocouple or simple temperature probe. Example of T_c point is shown on the photo below.



The lifetime of the module depends to operating temperature and used LEDs. If temperature at T_c will be lower than 65°C , the value of luminous flux shouldn't be less than 80% of its nominal value after 50.000h. If temperature is too high then lifetime can be significantly decreased or damage LEDs. Another disadvantage of high temperature is reduction of relative luminous intensity. LED modules produces heat. They must be provided with good air ventilation. Modules without air ventilation can overheat. Overheat can damage or destroy some elements or entire LED modules. We are not responsible for any loss, or damage resulting from improper use of modules! Guarantee become void in such cases.

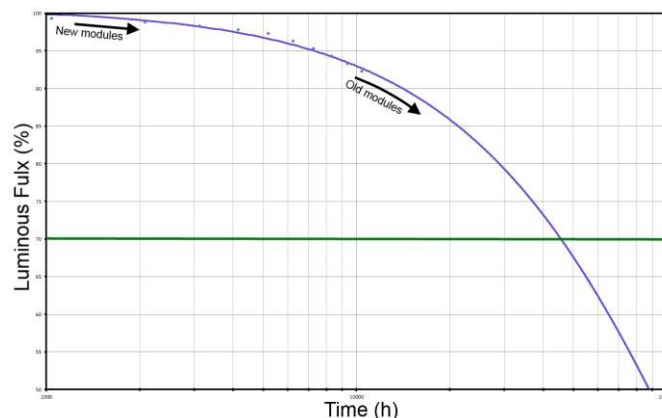

Most common problem using new modules in old installation is differences in brightness of modules. This is result of luminous flux degradation over time of use. Degradation is normal effect and applies to all LEDs. This effect is different for each LEDs and can be only predicted by testing and estimation. It is complicate issue that mostly depends on temperature and current. Good solution to this problem is reduce of current in new modules, but degradation will be different for each modules. Above characteristic is examples for LEDs in temperature above 100°C and different from the actual.

